

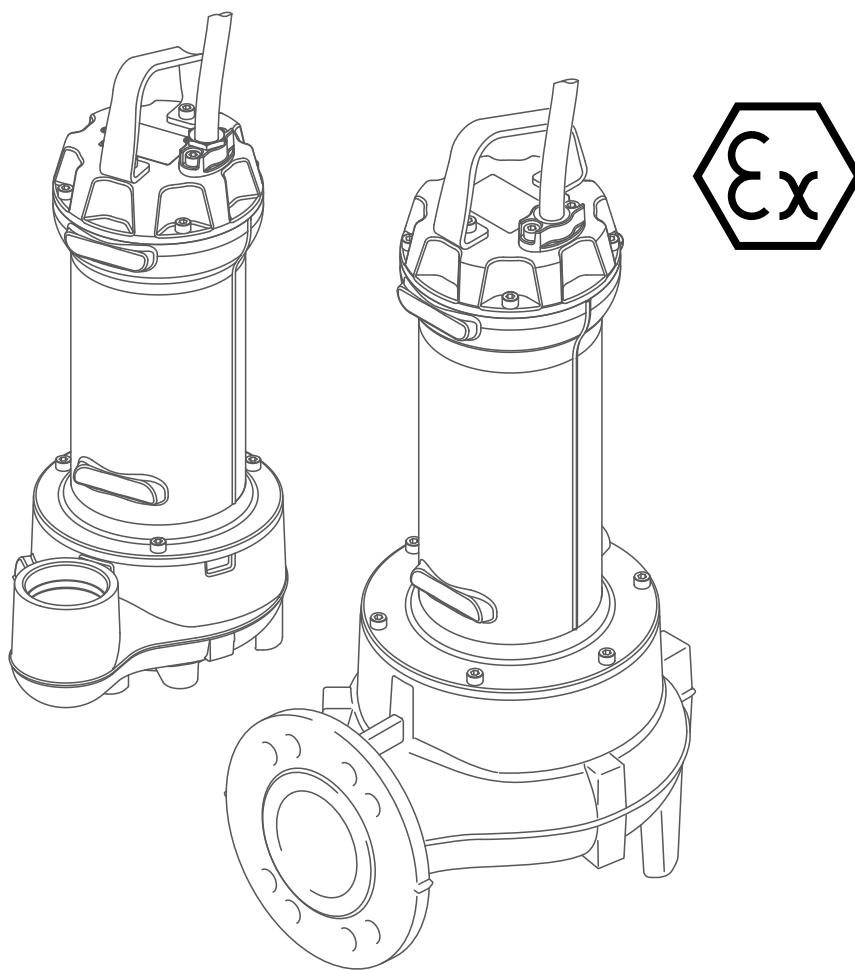

water solutions

# Grey



**IT** Le immagini sono puramente indicative e potrebbero non corrispondere all'aspetto reale del prodotto. I dati riportati potrebbero differire da quelli reali. Zenit si riserva la facoltà di apportare modifiche al prodotto senza alcun preavviso. Per ulteriori informazioni consultare il sito [www.zenit.com](http://www.zenit.com).

**EN** The images are indicative only and may not match the actual product. Details given here may differ from the actual product. Zenit reserves the right to modify the product without prior warning. For more information, consult the website [www.zenit.com](http://www.zenit.com).

**IT** ETICHETTA DI IDENTIFICAZIONE

**EN** DATA LABEL

APPLICARE QUI - AFFIX HERE

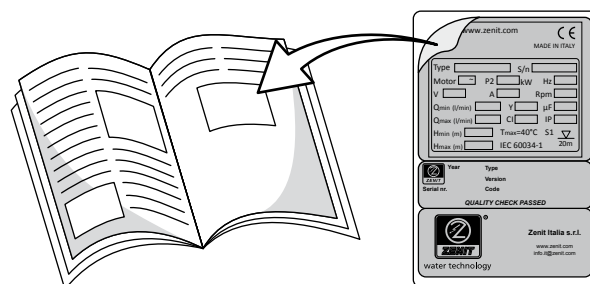

**For correct installation and safe use of the product, read this manual carefully and keep it safe in a clean, easily accessible place for future reference.**

**Misuse of the product may cause even serious injury and damage, cause malfunctions and lead to loss of warranty cover.**

## 1. GENERAL INFORMATION

### 1.1 Manufacturer's details

ZENIT Italia s.r.l. - via dell'Industria, 11 - 41018 S.Cesario sul Panaro (MO) – Italy

### 1.2 Key to the symbols used in the manual



Hazard for operators and pump



Electrical risk



Very hot surfaces with burn hazard



If failure to comply with this rule may cause hazardous of ignition with consequent risk of firing and explosion.

**WARNING!**

Important information to be read with special care



### 1.3 Safety

The main information for the safety of the product and user is provided in the "Safety Information" leaflet supplied with this manual.

### 1.4 Training of installation and maintenance staff

The staff assigned to install and maintain the product must be trained in the inevitable residual risks related to electrical equipment operating in contact with biological liquids.

They must also be capable of reading and understanding the contents of the technical documentation supplied with the product, especially the electrical wiring diagrams.

### 1.5 Residual risks

The product is designed and manufactured to ensure safe, reliable use.

However, since it is intended for use with liquids that constitute a health hazard, the installation and maintenance staff must take great care and always wear regulation personal protection equipment.

During all work on the product, users must take care not to drop the pump and must not underestimate the risks of burns, electrocution, drowning and suffocation or poisoning due to the inhalation of toxic gases.



To reduce the risks associated with lightning, the user is required to install any necessary and adequate lightning protection measures.



Any intervention which modifies the pump components can create a DANGER of EXPLOSION.

The pumps MUST be used ONLY in areas compatible with the characteristics recorded on the label.



During handling, installation or disinstallation operations the pump must be disconnected from the power supply panel.

### 1.6 Product description / Intended use

Grey submersible pumps are classified depending on the hydraulic type.



**Grey submersible pumps must under no circumstances be used to pump explosive, flammable or combustible liquids.**

- DGG Grey series: electric pumps with set-back Vortex impeller which allows ample free passages.  
Applications: biological liquids and wastewater civil and industrial lifting, wastewater treatment plants and livestock farms;
- DRG Grey series: electric pumps with Open Channel impeller.  
Applications: recirculation of industrial and process waters, civil lifting, drainage and lifting of water from first rainfall tanks;
- GRG Grey series: electric pumps with multi-channel open impeller with a grinding system.  
Applications: lifting of liquids containing fibres and filaments, professional and industrial applications, livestock farms;
- APG Grey series: electric pumps with high-head immersed multi-channel open impeller.  
Applications: lifting of clean liquids or liquids with small solids or sand, slightly sandy seepage waters.



The explosion proof versions are usable in places with a potentially explosive atmosphere, other than mines susceptible to firedamp (Gas Group IIB and IIA).



**WARNING!**

**The -Ex approval lapses following interventions or repair work carried out by unauthorised workshops or staff. Accordingly, the electric pump can no longer be used in areas with an explosion danger. The -Ex plate will have to be removed.**

### 1.7 Warranty cover

Zenit undertakes to repair or replace the product if failures are due to design, manufacturing and assembly defects and are reported to Zenit during the warranty period.

The warranty does not cover failures due to:

- normal wear and tear;
- improper handling, installation and use;
- use with incorrectly connected control systems;
- work done by unskilled staff;
- use of non-genuine spare parts.

**WARNING!** Any modifications made to the product without the manufacturer's authorisation may cause hazards and lead to a deterioration in performance and loss of warranty cover.

**Ex** The responsibility of repair, overhaul or maintenance to the pump in -Ex versions lies with the user of the product: make sure that any interventions is carried out by an Ex-Certified Service Centre (according with international and/or local standards and rules) or by a Zenit Service Centre.

### 1.8 Technical data

The product's technical data and characteristics are provided in the technical data sheet.

#### **Ex** 1.8.1 Operating conditions

For correct use, comply with the following operating conditions:

- Liquid/Ambient temperature: 0 ÷ 40°C
- pH value: 6 ÷ 14
- Duty service: S1 operation (continuous operation), the pump must always operate fully submerged
- Starts per hour mode: maximum 20 for motor with rated power P2 up to 10 kW, 15 for P2 over 10 kW

**Ex** The -Ex version pump can be used with a frequency converter (inverter) with the compulsory condition that the thermal protector inside the motor are correctly connected to the control panel (for non -Ex panels, outside of the risk area).

### 1.9 Name plate on the pump

On the motor cover you find a metal plates which states the operating data and approvals applying to the pumps.

With this manual, a sticky label containing the product features found on the metallic plate affixed to the electric pump has been provided.

We recommend that you put this label in the specific place provided within the manual and then refer to the data contained on the label for any requirements or information.

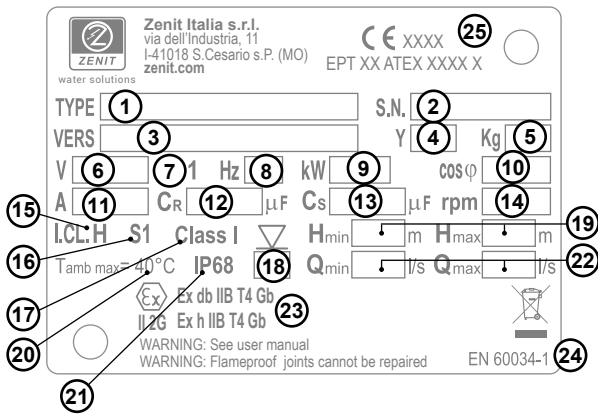

Fig. 1 A - Single phase

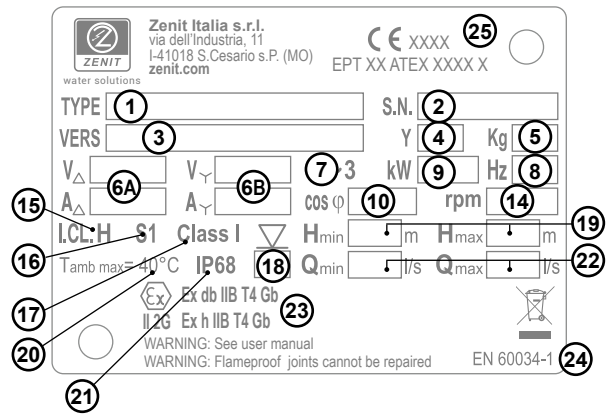

Fig. 1 B - Three phase

- |  |                            |   |
|--|----------------------------|---|
| 1. Product name                            | 8. Frequency               | 17. IEC protection class against electric shock |
| 2. Serial number                           | 9. Motor power output - P2 | 18. Maximum immersion depth                     |
| 3. Product version                         | 10. Power factor           | 19. Maximum and minimum head                    |
| 4. Year of manufacture                     | 11. Rated current          | 20. Maximum ambient temperature                 |
| 5. Weight                                  | 12. Run capacitor          | 21. Casing protection rating                    |
| 6. Rated voltage                           | 13. Start capacitor        | 22. Minimum and maximum flow-rate               |
| 6A. Voltage and current (delta connection) | 14. Rpm                    | 23. -Ex protection classification               |
| 6B. Voltage and current (Y connection)     | 15. Motor insulation class | 24. Motor reference standards                   |
| 7. Motor phases                            | 16. Duty type              | 25. -Ex certification number                    |

### 1.10 Explanation to -Ex approval

The Grey series have the following explosion protection classification

**CE** XXXX CE marking of conformity according to the ATEX directive 2014/34/EU  
 XXXX stand for the number of the notified body (marked on the plate) which has certified the quality system for ATEX

**Ex** II 2G (Only for ATEX)  
 Ex db IIB T4 Gb  
 Ex h IIB T4 Gb

**Ex** The specific marking of explosion protection given in the Annex II of the Directive 2014/34/EU  
 II Group of the equipment. Group II: electrical equipment for use in places with an explosive gas atmosphere other than mines  
 2G Category of the equipment subject of certification, in presence of potentially explosive atmospheres of Gas, Vapors, Mist (G).  
 The equipment can be installed in ZONE 1  
 Ex db IIB The type of electrical protection for the equipment is a flameproof enclosure, suitable for Gas Group IIB and IIA.  
 Ex h IIB The type of mechanical protection for the equipment is through liquid immersion “k” and constructional safety “c”, suitable for Gas Group IIB and IIA.  
 T4 Temperature Class of the equipment (maximum surface temperature 135°C)  
 Gb Equipment for explosive gas atmospheres, having a “high” level of protection, which is not a source of ignition in normal operation or during expected malfunctions

### 1.11 Product's name description

DGG 300/2/G65V C0ET5  
 ① ② ③ (A) (B) (C) ④ ⑤ ⑥ ⑦ ⑧ ⑨

- |   |  |
|---|--|
| ① Family<br>② Series<br>③ Power (HPx100) / motor poles<br>④ Pump outlet<br>(A) TYPE (GAS thread/Flanged)<br>(B) DIAMETER (mm)<br>(C) POSITION<br>V = vertical<br>H = horizontal | ⑤ Hydraulic model<br>⑥ Version number<br>⑦ Motor size<br>⑧ Motor phases<br>M = Single-phase<br>T = Three-phase<br>⑨ Power supply voltage frequency<br>5 = 50Hz<br>6 = 60Hz |
|---|--|

### 1.12 Decals applied to the product

**Fig. 2** - Decal indicating correct impeller rotation direction viewed from above (three-phase models only)

**Fig. 3** - Silver sticker. Reproduces the nameplate affixed to the product. It must be stuck into the space provided in this manual and be referred to when making any requests or enquiries.

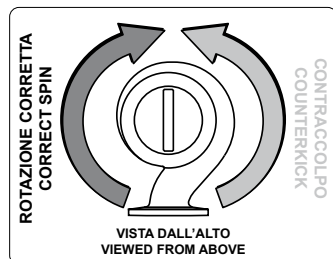

Fig. 2

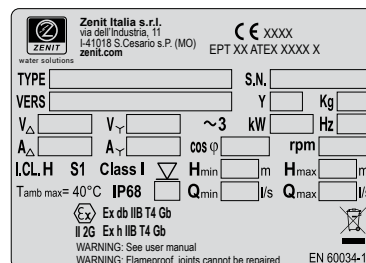

Fig. 3

## 2. TRANSPORT AND INSTALLATION

### 2.1 Visual inspection

Make a visual inspection of the packaging for damage. Record any significant damage to the product in the transport documents.

If articles are missing, contact Zenit (or its dealer) or the forwarders.

Remove the packaging materials and dispose of them as required by law. Take special care not to injure yourself with sharp tools and not to damage to the product, especially the electrical wiring.

Inspect the product to ensure that there are no damaged or missing parts.

Check that the data on the nameplate are the same as those of the product required.



### 2.2 General safety precautions

- Fence off the working area by appropriate means and wear personal protection equipment.
- Before carrying out any operation, make sure that the pump and electrical panel are disconnected from the electrical mains and cannot be accidentally powered up.
- Check the electric cable and gaskets for damage and make sure that the impeller turns freely.
- The size of the tank in which the pump is installed must be such that:
  - any level float switches are able to move freely;
  - the number of pump switch on/switch off cycles does not exceed the permitted number stated in the technical information;
- The pump must be lowered into the tank using a sling or chain of suitable size tied to the handle.
- Prior to installation, make sure the tank bottom is even.
- To prevent the cavitation problems caused if the pump draws in air, ensure that the liquids do not flow into the tank near to or towards the pump.
- Make sure that the pump does not operate off its characteristic curve.
- Bolts used for replacement must be Class A2-70 or better according to EN ISO 3506-1



**Make sure that the atmosphere in the working area is not potentially explosive.**

**Persons must not enter the installation area when the atmosphere is explosive.**

**The classification of the installation site must be approved by the local fire-fighting authorities in each individual case.**

**Grey submersible pumps shall be installed in vertical operating position.**

**The user must ensure that the -Ex pump operates always submerged. The minimum level of pumped liquid must be controlled by two level sensors (in redundancy) to shut down the power supply when the liquid to be pumped belows the minimum level (pump fully submerged).**

**The electric pump is equipped with thermal protectors inside the stator windings to shut down the power supply in case of overheating. It is mandatory that the user connect thermal protectors with a control panel set in a way to avoid the automatic restart of the submersible pump. The pump shall be exclusively restarted manually by a technician after having fixed the causes of the anomaly.**

**The shock from built up electrostatic charges on isolated components could cause an explosion. -Ex pumps do not have isolated components that are electrostatically chargeable and they are all equipped with screw for connection to the equipotential ground network. Any additional components installed in the hazardous area must be connected to the earthing network according to the EN 1127-1 rule, part 6.4.7.**

**Check the suitability for use in potentially explosive atmospheres of each additional component installed in the hazardous area.**

**Prior to installation, check the oil level in the mechanical seals oil chamber.**



### 2.3 Handling and lifting

The pump must be lifted and handled using a chain or sling secured to the handle on top, with suitable machinery (crane, hoist, etc.).

Before lifting, make a note of the weight of the product stated on the nameplate and use certified slings, chains and hooks of suitable load capacity.

Ensure that the electric pump is firmly secured and cannot fall, rotate or swing.

The handle on top is designed to ensure that the pump will be balanced during lifting; however, it may swing when lifted off the ground (Fig. 4).

Do not stand close to the pump during handling.

Always wear personal protection equipment.

**WARNING!**

**NEVER handle the product by means of the power supply or signalling wiring.**

### 2.4 Checking the impeller rotation direction

Before making the definitive electrical connection, a skilled technician must make sure the impeller rotation direction is correct.

The three-phase pump carries a decal which indicates the correct impeller rotation direction (green arrow) and the relative kickback direction (red arrow) when the pump is viewed from above (Fig. 2).



**All of the following operations must be carried out in safety area, in absence of potentially explosive atmospheres.**

Proceed as follows:

1. Take the precautions detailed in the "Safety Precautions" manual.
2. Place the pump vertical on its feet or base.

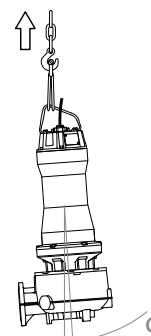

Fig. 4

3. Secure the pump by tying a suitably sized chain or sling to the handle on the top to prevent it from falling over after the kickback.

**WARNING!** The kickback may be very strong. Do not stand close to the pump during the procedure.

4. Temporarily connect the yellow-green wire to the system ground connector and then connect the power supply wires to the contactor.
5. Make sure there are no people or objects within a distance of at least 2 metres of the pump.
6. Operate the start switch, power up the pump for a few seconds and then shut off the power by flicking the stop switch.
7. Check that the rotation direction is correct.

If the pump is rotating in the wrong direction, invert two of the pump's three power supply phases and try again, repeating the procedure described. Once the connection which provides the correct rotation direction has been obtained, MARK the precise order in which the wires have been connected to the system, DISCONNECT the power supply wires from the pump and proceed with definitive installation.

**WARNING!** If more than one pump is connected to a single control panel, the rotation direction must be checked individually for each unit installed.

### 2.5 Installing the float switch control system (Fig. 5)

Float switches allow one or more pumps to be started and stopped in response to the level of liquid in the tank. They can also be connected to alarm devices to prevent operational problems (overflow or dry running). They must be installed well away from turbulence or inflows of water.

In the event of strong turbulence, float switches should be installed on a rigid rod mounted inside the pit.

Make sure that there are no items which may obstruct movement of the floats and that the wires do not interfere with each other, and cannot become tangled or trapped on projections inside the tank.

Float switches must be installed in such a way that the correct minimum liquid level is guaranteed.

 The minimum liquid level must be controlled by two float switch (in redundancy) to shut down the power supply when the liquid to be pumped belows the minimum level (pump fully submerged). Only use float switch sensor according with the classification of the installation site. The connection to the electric control panel must be carried out using an Intrinsic Safe Circuit such as a Zener safety barrier or a galvanic isolation barrier.

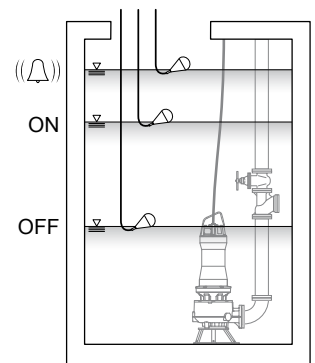

Fig. 5

Ensure that the switch **from shut down to start-up** occurs only and exclusively if all the floats find themselves in the position shown in Fig 6. Ensure that the switch **from start-up to shut down** occurs only and exclusively if both of the floats find themselves in the position shown in Fig 7.

Make sure that effective volume of the tank does not become so low that the number of starts per hour exceeds the maximum admitted.

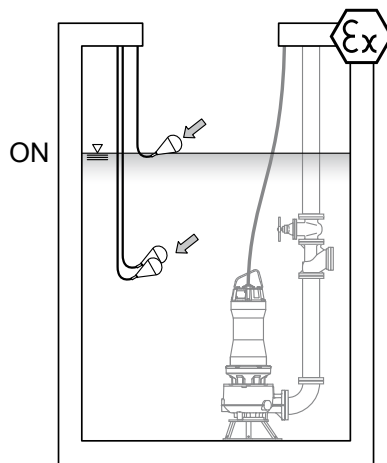

Fig. 6

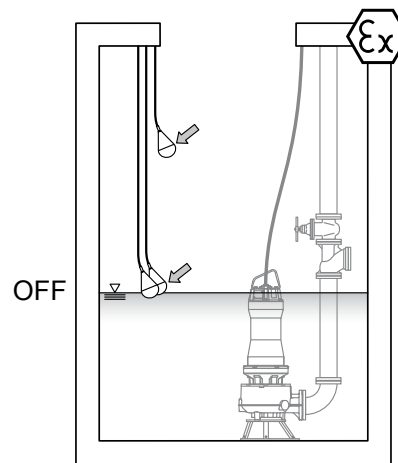

Fig. 7

## 2.6 Permitted installation types



Make sure that the atmosphere in the working area is not potentially explosive.

### 2.6.1 Installation with DAC coupling device

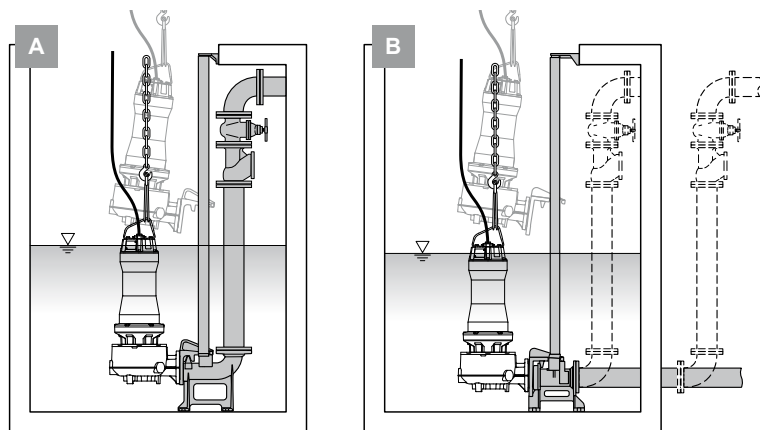

Fig. 8

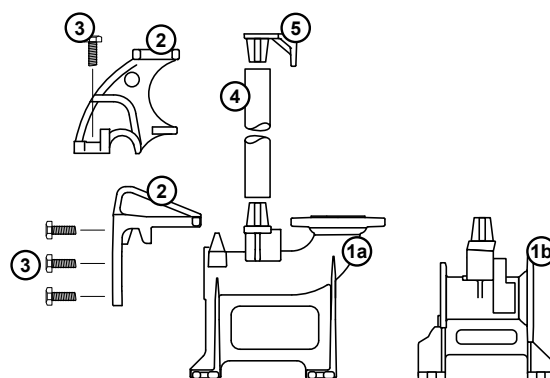

Fig. 9

With this type of installation (Fig. 8), the pump can be removed from and replaced in the tank quickly without any work on the system.

#### System components (Fig. 9):

- 1a. DAC V coupling device (vertical outlet)
- 1b. DAC H coupling device (horizontal outlet)
2. Coupling flange or hook (changes depending on pump model)
3. Screws
4. Pipe guides (not included)
5. Spacer bracket

#### Installation procedure (Fig. 10)

1. Check that the pump is disconnected from the power supply panel and the impeller turns in the correct direction using the procedure described in point 2.4 “Checking the impeller rotation direction”.
2. Fix the flange to the pump’s outlet port with the screws provided. For models with hooks, fix the hook to the pump body using the screws provided.
3. Place the coupling device on the bottom of the tank and mark the position of the holes required to fix it.

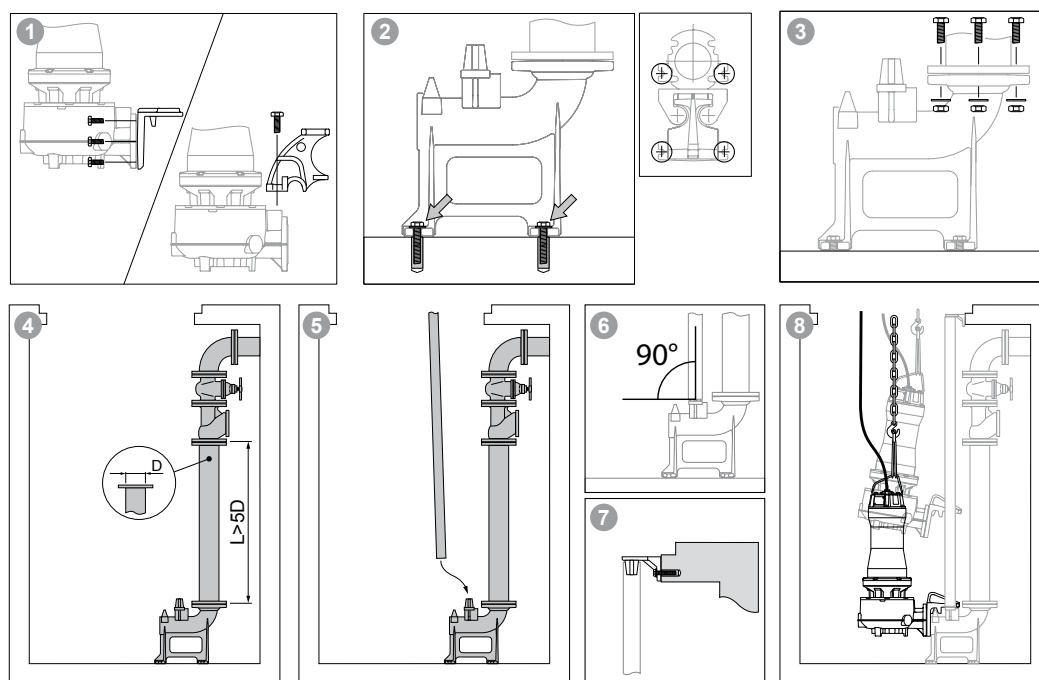

Fig. 10



4. Make holes of suitable diameter for the coupling device fixing slots and secure it firmly to the bottom of the tank using chemical or expansion plugs. Use stainless steel metal fasteners or protect the screws and nuts with a suitable product to prevent corrosion.
5. Connect the outlet pipeline to the coupling device. A shut-off valve and a ball type check valve with full free passage should be installed using a connection pipe with length equal to at least 5 times the diameter of the outlet.
6. Fit the pipe guides, cut to the correct length, to the coupling device. Galvanised steel pipes, or preferably stainless steel pipes, of suitable diameter can be used (see technical information).
7. Connect the spacer bracket to the top end of the pipe guide and mark the positions of the holes required to fix it to one of the sides of the tank; make sure that the pipe guides are perfectly vertical with the aid of a plumb-line or a spirit-level.

**WARNING!** Before connecting the bracket spacer check, by lifting the pump up, if it is possible to extract the coupling flange from the pipe guides (Fig. 11).

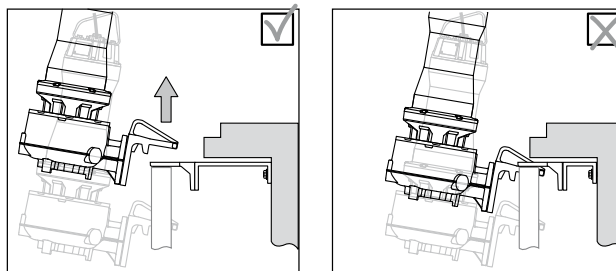

Fig. 11

8. Make holes of suitable diameter for the spacer bracket fixing slots and secure it firmly using chemical or expansion plugs. Protect the screws and nuts with a suitable product to prevent corrosion.
9. Clean the tank to remove any remaining debris and waste.
10. Secure a chain or sling of suitable size to the handle and lower the pump into the tank, sliding the flange along the pipe guides until it reaches the coupling device.
11. Secure the electric cables so that they cannot be twisted or torn or drawn in by the pump.
12. Bring the cables out of the tank through a clean, smooth duct. Do not lay cables with tight bends or in positions with risk of crushing or damage.
13. Connect the electric cables to the control panel as shown in the diagram provided in point 3.2 "Connection diagrams".

## 2.6.2 Mobile installation

In mobile installation (Fig. 12) the pump is mounted on a specific base which keeps it vertically on the bottom of the tank and ensures that the intake is at the correct height.

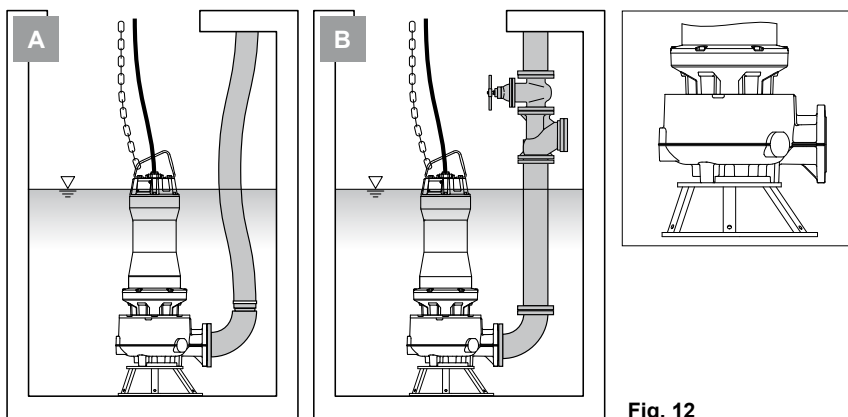

Fig. 12

### Installation procedure (Fig. 13)

1. Check that the pump is disconnected from the power supply panel and the impeller turns in the correct direction using the procedure described in point 2.4 "Checking the impeller rotation direction".
2. Lower the pump onto the base using a chain or sling of suitable strength secured to the handle. Ensure that it cannot fall and/or swing.
3. Secure the pump to the base with the screws provided.
4. Connect the outlet to the piping using the standardised flange. Use stainless steel metal fasteners or protect the screws and nuts with a suitable product to prevent corrosion. A shut-off valve and a ball type check valve with full free passage should be installed using a connection pipe with length equal to at least 5 times the diameter of the outlet. If a hose is used, fit a flanged hose connector. A hose with reinforcing coil or semi-rigid hose is recommended to ensure that the free passage remains constant even at bends in the hose or points where it changes direction. Secure the hose to the union by means of a metal band clamp.
5. Lower the pump into the tank until it rests firmly on the bottom using a chain or sling of suitable strength secured to the handle. Ensure that the pump cannot fall and/or swing.
6. Secure the electric cables so that they cannot be twisted or torn or drawn in by the pump.
7. Bring the cables out of the tank through a clean, smooth duct. Do not lay cables with tight bends or in positions with risk of crushing or damage.
8. Connect the electric cables to the control panel as shown in the diagram provided in point 3.2 "Connection diagrams".

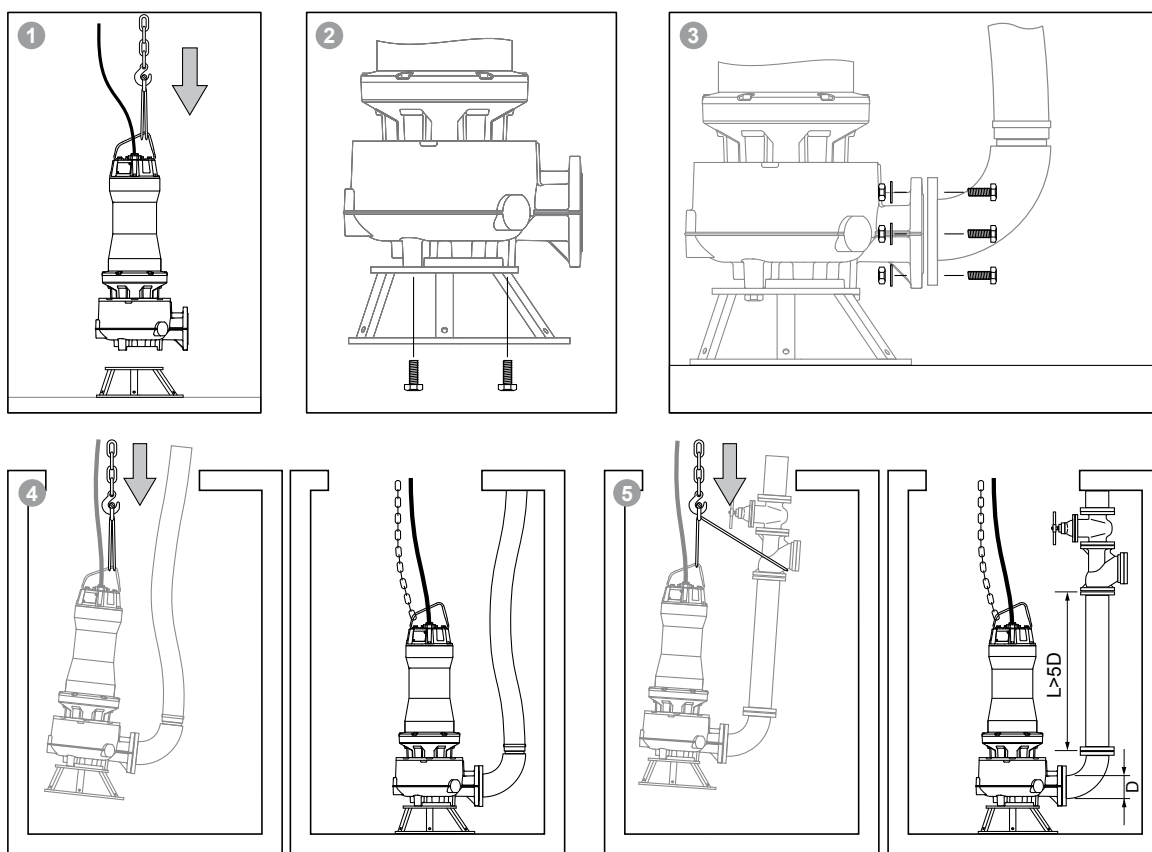

Fig. 13

### 3. ELECTRICAL CONNECTIONS



#### 3.1 General safety precautions

- All the procedures involved in connecting the unit to the electrical mains must be carried out by skilled staff in accordance with the relevant legal requirements: incorrect electrical connections may cause fires and an electrocution hazard, or the risk of damage to the product.
- Check that the unused conductors are properly insulated and fixed in the electrical panel.
- Before installation, make sure that the power supply line voltage and frequency are as stated on the nameplate and that the power absorption of the pump is below the maximum current the system is able to deliver.
- The maximum voltage variation allowed for rated value is  $\pm 5\%$
- Voltage imbalance between phases: max 2%
- The fuses and protective cut-outs must be of suitable rating for the system's characteristics.
- Protect the pump motor using an overload cut-out suitable for the electrical data provided on the nameplate.
- Make sure that the thermal protection devices are properly connected: apart from leading to forfeiture of warranty cover, failure to connect the thermal protection may constitute a hazard.
- The electrical operation and safety of ZENIT electric pumps are guaranteed for the configuration supplied by the manufacturer: any changes (e.g. addition of extra lengths of cable to the original power lead) may cause a deterioration in the pump's characteristics.



**Before installation and the first startup, make sure that the electrical cables are not damaged in any way to avoid short circuit.**

#### 3.2 Wiring

- Make sure that the electrical cables have not be exposed to damp and/or immersed in water.
- The cable's free terminals must be connected to a control panel with a degree of insulation suitable for the installation environment.
- Secure the electric cables so that they cannot be twisted, torn and/or crushed.
- If the cable is damaged, do not replace it; contact Zenit or an Authorised Service Centre.
- Do not underestimate the problems caused by voltage drops.



**The ends of the power supply cable must be connected to an electric panel certified for use in potentially explosive atmospheres if it is installed in a hazardous area**

### 3.3 Ground connection

- Make sure that the ground system and differential security breaker are present and in good working order.
- Check that the ground conductor is about 150 mm longer than the other conductors so that it will be the last to become disconnected from the panel in the event of accidental tugs.

The predisposition for the connection of the external earth conductor accepts cables with a cross-sectional area of at least 4 mm<sup>2</sup>.



**On -Ex pumps, make sure that an external earth conductor (yellow and green, with cross section at least of 4 mm<sup>2</sup>) is connected to the external earth terminal on the pump using a secure cable clamp. Clean the surface of the external earth connection and mount the cable clamp.**

### 3.4 Thermal protection

The equipment is equipped with thermal protectors inside the stator windings to shut down the power supply in case of motor overheating. The standard thermal protection consists of bimetal thermal protectors with nominal switching temperature NST=150°C; as option, bimetallic protectors can be replaced by PTC thermistors or PT100 sensors. The thermal protection cables are marked with a label stating “PROTEZIONE TERMICA - THERMAL PROTECTION” and must be connected to the corresponding terminals of the control panel.



**The connection of the thermal protectors to a control panel is mandatory. The electric panel must be predisposed to guarantee the shutdown of the motor when the thermal protection intervenes and to avoid the automatic start-up of the pump which must only be started manually with the intervention of an operator.**

### 3.5 Leakage detector

The electric pump can be equipped with a single-electrode leakage detector as an accessory to detect and signal the infiltration of water into the oil chamber of the mechanical seals (the equipment grounding conductor is used as the return path for the conductive level limit detection). In the case of detection, take out of service the pump and proceed with maintenance.

The signal cable is marked with a label with the letter **S**.



**For installations with -Ex certified models, the connection to the electric control panel must be carried out by inserting in safe area an Intrinsic Safety barrier with galvanic isolation.**

Electrical safety data for intrinsically safe circuit:

<u>Leakage detector</u>	Ui: 30V; li: 120mA; Pi: 1.3W
	Ci: 0.3nF; Li: ~ 0mH
<u>Cable</u>	Cc: 200pF/m; Lc: 1μH/m; Lc/Rc= 30μH/Ω

### 3.6 Connection diagrams (standard version)

To set up the electrical connection of the electric pump, do the following:

1. Check which type of electrical connection is required on the identification plate (direct starting or Y/D).
2. Firstly, connect the earth wire to the relative terminal in the electrical panel, according to the connection diagram illustrated.
3. Connect the power wires to the relative terminals in the electrical panel, according to the followings connection diagrams (please refer to the specific documentation supplied with the unit for electrical connections of non-standard sensors and protective devices).
4. Connect the wires of the control devices to the terminals on the relative panel.



*For electrical connection, refer to the diagram corresponding to the electric pump version indicated on the plate*

## ~1 50/60Hz

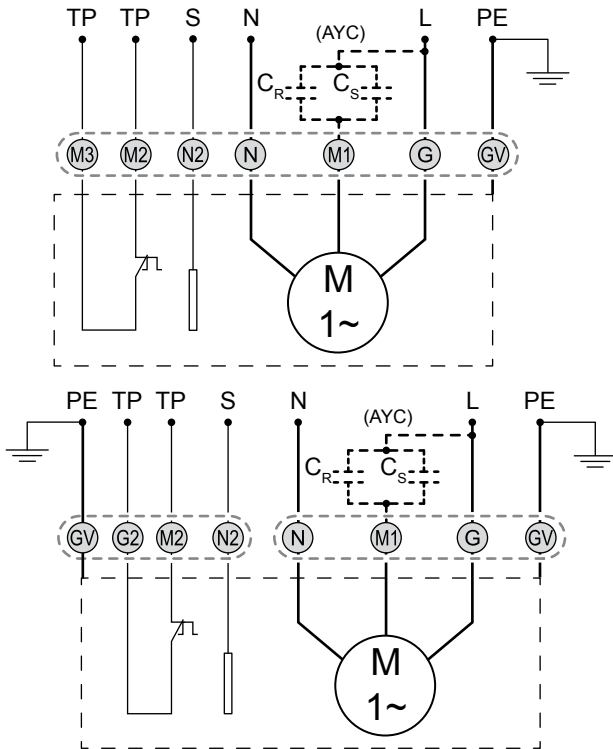
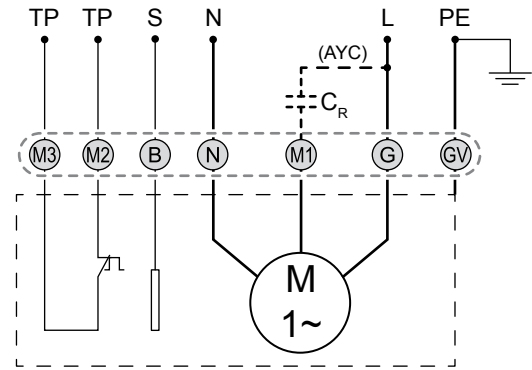
**TSCD**

**TSC**

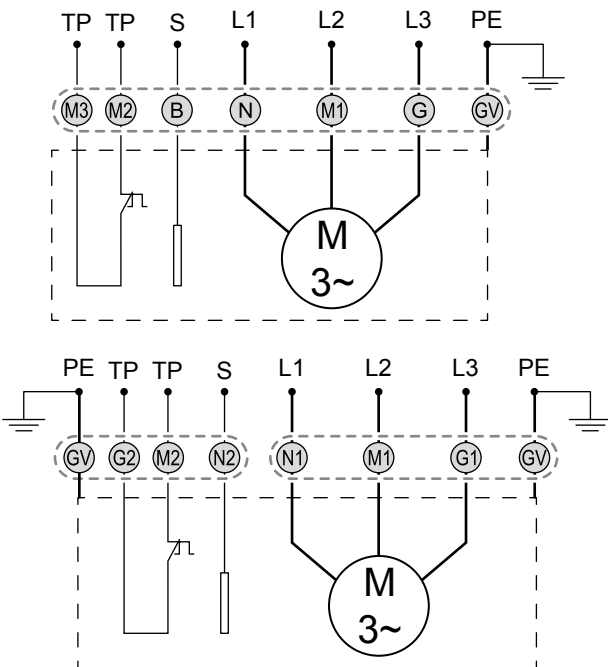
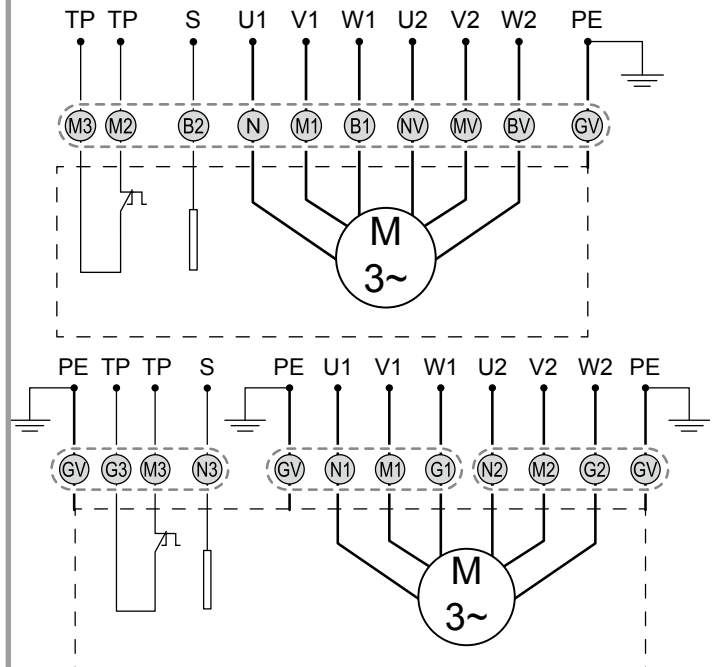
## ~3 50/60Hz

**TS**
**DOL**

**TS**
**Y Δ**

L - N	L1 - L2 - L3	U1 - U2 V1 - V2 W1 - W2	C <sub>R</sub>	C <sub>S</sub>	TP	S	PE	NC
Single-phase power supply	Three-phase power supply	Motor terminals	Run Capacitor	Start Capacitor	Thermal protection	Probe	Ground	Not connected

**Key of color code:**

**AYC** At your care

## 4. COMMISSIONING



### 4.1 General safety precautions

- All operations must be carried out by skilled technical staff.
- Keep objects and people at a safe distance from the machines installed and do not allow people or animals to come into contact with the liquid in which they are immersed.
- Before carrying out any operation, make sure that the pump and electrical panel are disconnected from the electrical mains and cannot be accidentally powered up.
- Before connecting the pump to the power supply panel, check that the impeller can turn freely.
- Check the level and the condition of the oil in oil chamber.
- Check that the impeller turns in the correct direction using the procedure described in point 2.4 "Checking the impeller rotation direction".

### 4.2 Starting the electric pump



**The pumps must not be started if the atmosphere in the tank is potentially explosive.**

Once installation is complete, the system should be tested to ensure that it is fully operational.

The pump must always be used with the safety devices installed and in good working order; make sure that all protective equipment has been connected correctly.

The pump must not run dry; check that the liquid level is above the motor.

Check that the required gate valves (where fitted) function are open.

Switch on the power supply and let the pump run briefly and:

- check that the input current is within the limit stated on the nameplate;
- check whether the monitoring units are operating satisfactorily (no alarms or warnings);
- check the setting of the level control system (minimum and maximum levels).

#### **WARNING!**

**The maximum permitted number of starts per hour must be complied with to prevent damage to the motor.**

*In case of abnormal noise or vibration from the pump, other pump failure, alarms or warnings, stop the pump immediately and do not restart it until the cause of the anomalies are found and fixed.*

### 4.3 Acoustic pressure level

The pump's acoustic pressure level when in operation is below 70 dB.

However, in some systems and in some duty points on the performance curve this threshold may be exceeded.

Check the permitted acoustic pressure level in the environment where the product is installed to avoid breaching local legal requirements.

## 5. MAINTENANCE AND SERVICE

### 5.1 Introduction

Zenit electric submersible pumps undergo through final inspection before they are offered for sale and installed.

The product's reliability derives from the use of top quality components but also depends on regular inspections which must be carried out by the user.

#### **WARNING!**

**The instructions for inspection and maintenance of these pumps must never be viewed as "Do-it-Yourself" procedures; they require specific technical knowledge.**



**Any interventions of the pump in -Ex versions must be carried out by an Ex-Certified Service Centre (according with international and/or local standards and rules) or by a Zenit Service Centre by trained technicians using only original spare parts.**

Failure to comply with this rule causes loss of -Ex approval.



### 5.2 General safety precautions

- Take the precautions detailed in the "Safety Precautions" manual.
- Before cleaning and/or maintenance procedures, a skilled technician must disconnect the pump from the power supply and ensure that it cannot start up accidentally.
- Always disconnect the phase wires first and then the yellow-green ground wire.
- Ensure that the pump cannot fall or roll, causing injury or damage.
- Wash the surface of the pump thoroughly with clean water and/or specific detergent before doing any work on it.
- After prolonged use, the surface of the pump may become very hot: allow it to cool sufficiently to avoid burns.
- Always comply with the safety regulations in force in the place of installation, any local regulations and the dictates of common sense.

### 5.3 Planned maintenance and service

Maintenance intervals depend on the type of installation, the workload to which the pump is subjected and the type of liquid in which it is immersed. During planned maintenance or in any circumstances when the pump's performance deteriorates or its vibrations and noise level increase, the parts subject to wear and tear must be inspected; have this done by an Authorised Service Centre.

**Do not use the pump if malfunctioning because sudden failure of the rotating parts may cause hazardous situations or damage to the motor.**

If the hydraulic part is fouled, clean it thoroughly.



**Pumps in normal operation must be inspected every 4000 hours of operation or at least once a year. If the pumped liquid is very muddy or sandy, a short inspection period is necessary.**

**Check the wear conditions of the bearings, the mechanical seals and all other parts subject to wear, since particularly unfavorable or incorrect installation conditions can be a cause of ignition hazard.**

**A maintenance plan with a maximum interval of 2 years must be scheduled; re-conditioning must include the replacing of bearings, mechanical seals (oil change included) and worn pump parts. Do not reuse rubber parts.**

If the pump is used only occasionally, after each use flush out the hydraulic part to prevent the formation of deposits; run the pump for a few cycles with clean water.

Also take care not to allow sediments to form on the float switches, to ensure that the start and stop thresholds remain correct.

#### 5.4 Inspection

- **Bearings inspection**

All bearing are rolling element type grease lubricated for life. Check the shaft noisy or heavy operation (turn the shaft by hand) and in case, replace the defective ball bearings.



**Defective bearings may reduce the -Ex safety.**

- **Mechanical seals inspection**

When the pump is new or after mechanical seals replacement, check the oil level. The oil must be changed after 4,000 operating hours or once a year. Oil change and mechanical seals inspection is necessary if the leakage probe detects an ingress of water into the seal chamber. Oil chamber is designed in order than, filling it with the pump in vertical position, the right quantity of the lubricate is reached when its level reach the hole for the filling (oil plug).

Use CASTROL PRODUCT L320 oil or similar.

- **Cable inspection**

Make sure that the electrical cables aren't sharply bent and/or pinched or damaged in any way.

## 6. TROUBLESHOOTING GUIDE

	PROBLEM	POSSIBLE CAUSE	SOLUTION
1	The pump doesn't start	No power supply	Check power supply line.
		Damaged or disconnected cable	Check the cable connections and make sure that it's not damaged.
		Fuses blown	Check fuses type and rating and replace them with correct ones.
		Tripped circuit breaker	Refer to Point 3.
		Tripped thermal protector	Refer to Point 2.
		Damaged or wrongly connected capacitor (single phase motor)	Replace the capacitor and check that it's correctly connected.
		Tripped level control	Check that the level sensor is correctly connected and functioning
		Broken, burned or disconnected wiring	Check the status of wiring and connections.
2	The thermal protection trips after a short operating time	The pump is immersed in a liquid which is too hot	Cool down the liquid.
		Clogged hydraulic	Clean the hydraulic parts and remove the blocking material
		Blocked rotor	Contact an authorised service center.
		Uncorrect voltage	Check that the supplied voltage matches with the one on the pump's nameplate
		Fault in bearings	Contact an authorised service center.
		Starts per hour exceed the permitted number	Refer to Point 6
3	Tripped circuit breaker	High drop voltage	Reestablish the correct voltage supply.
		Low voltage supply	Measure the voltage supply. Reestablish the correct voltage supply.
		Clogged hydraulic	Clean the hydraulic parts and remove the blocking material
		Blocked rotor	Contact an authorised service center.
		Short circuit in the motor winding	Contact an authorised service center.
		Wrong electrical connection	Check and correct the electrical installation.
		Low setting of the thermal relay	Set the relay in accordance with the rated current on the nameplate

4	Tripped residual current device (RCD)	Low motor winding insulation	Contact an authorised service center.
		Fault in cable	Have the cable checked and repaired by a qualified electrician.
5	The pump operates but the flow is low or null	Clogged hydraulic	Clean the hydraulic parts and remove the blocking material
		Clogged outlet pipe	Clean the outlet pipe.
		Blocked non-return valve	Clean the non-return valve.
		Outlet valve blocked or closed	Open and/or clean the outlet valve.
		Wrong direction of rotation	Check the direction of rotation, interchange any two of the phases.
		Leakage in the pipeline	Check the pipeline and fix the leakage causes.
		Wrong pump selection	Replace the pump with a suitable one.
6	Starts per hour exceed the permitted number	Wrong setting of the level control	Correct the level control setting.
		Level control malfunction	check the level sensors functionality.
		Turbulence near the level sensors	Remove the causes of turbulence or change the positioning of the level sensors.
		Undersized tank	Adjust the tank dimension.
7	Noisy operation and excessive vibrations	Fault in bearings	Contact an authorised service center.
		Damaged impeller	Contact an authorised service center.
		Blocked impeller	Clean the hydraulic parts and remove the blocking material
		Wrong direction of rotation of the impeller	Check the direction of rotation, interchange any two of the phases.
8	The pump works correctly but absorbed current is too high	Wrong duty point	Make sure the pump operates within its operative range
		Wrong voltage supply	Reestablish the correct voltage supply.
		Clogged hydraulic	Clean the hydraulic parts and remove the blocking material
		Fault in bearings	Contact an authorised service center.
		Wrong direction of rotation of the impeller	Check the direction of rotation, interchange any two of the phases.
9	Leakage detection	Water ingress in the motor due to damaged cables, o-rings or cable glands.	Contact an authorised service center.
		Water ingress in the mechanical seal chamber due to wearing or breaking down of mechanical seals or o-rings	Contact an authorised service center.

## 7. MAIN COMPONENTS

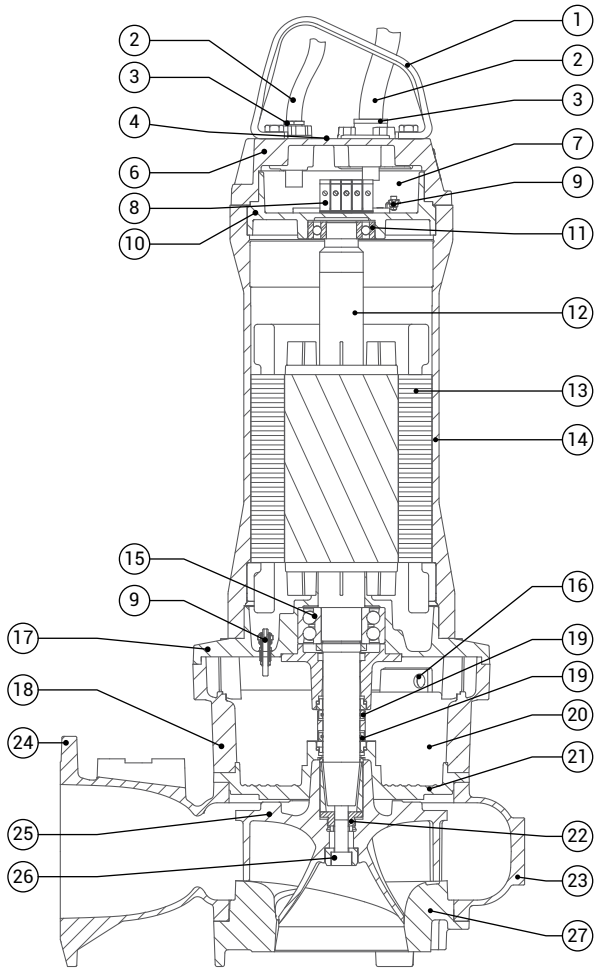

Enclosure type M\_

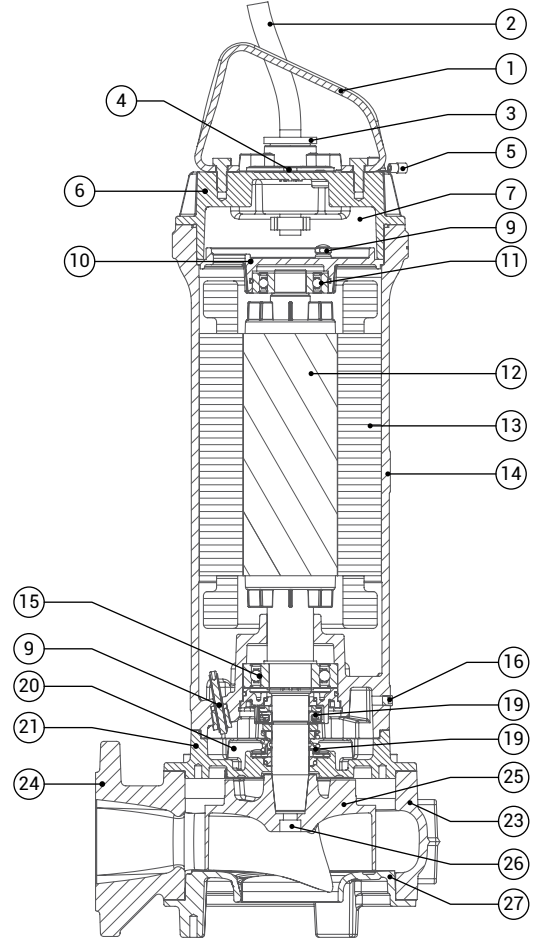

Enclosure type G\_

1 Handle	10 Upper bearing support	19 Mechanical seal
2 Cable	11 Upper bearing	20 Oil chamber
3 Cable gland	12 Shaft with rotor	21 Pump plate
4 1/8" NPT blanking element	13 Stator	22 Bush
5 Earth connection	14 Motor case	23 Pump body
6 Motor cover	15 Lower bearing	24 Outlet flange
7 Terminal case	16 Oil plug	25 Impeller
8 Terminal	17 Lower bearing support	26 Impeller fixing screw
9 Probe	18 Intermediate support	27 Suction flange

The product's outline is purely illustrative









water solutions

[zenit.com](http://zenit.com)

27270100923200000  
Rev. 0 - 01/07/19